

Reference numbers for spare parts of machine

- | | |
|---------------------------|----------------------------|
| 1-Collar | 36-Motor protection relay |
| 2-Head/dosing cylinder | 37-Emergency button |
| 3-Piston | 38-Closing bottom panel |
| 4-Gasket PK 35 | 39-Foot |
| 5-Front insert | 40-Operating dosing switch |
| 6-Cover button | 41-Activation block |
| 7-Connecting rod | 42-Front lever handle |
| 8-Key | 43-Front lever |
| 9-Articulated joint | 44-Pedal plug/syringe |
| 10-Fixing pivot | 45-Pedal/syringe tap |
| 11-Elastic washer | 46-Pilot-light |
| 12-Dosing index | 47-Fixing head block |
| 13-Window | 48-Frontal screws |
| 14-Cover | 49-Head gasket OR-Ring |
| 15-Cam | 50-Protectin needle Ø 8 mm |
| 16-Regular lever | 51-Single needle |
| 17-Hinge | 52-Little Valve |
| 18-Nut hinge | 53-Screw |
| 19-Seal | 54-Cover head |
| 20-Safety micro-switch | 55-Gasket clamp 2 ½ |
| 21-Bearing support | 56-Hopper |
| 22-Bearing | 57-Plug CEE |
| 23-Reducer axis | 58-Cable pedal |
| 24-Clamp 2 ½ | 59-Pedal |
| 25-Cable presser | 60-Double needle Ø 6 mm |
| 26-General switch | 61-Protecton needle Ø 6 mm |
| 27-Dosing micro-switch | 62-Single needle Ø 6 mm |
| 28-Commutator | |
| 29-Dosing cam | |
| 30-Self-locking ring nut | |
| 31-Reducer | |
| 32-Electrical module | |
| 33-Motor | |
| 34-Electrical transformer | |
| 35-Remote control switch | |

Functional Diagram of the Machine

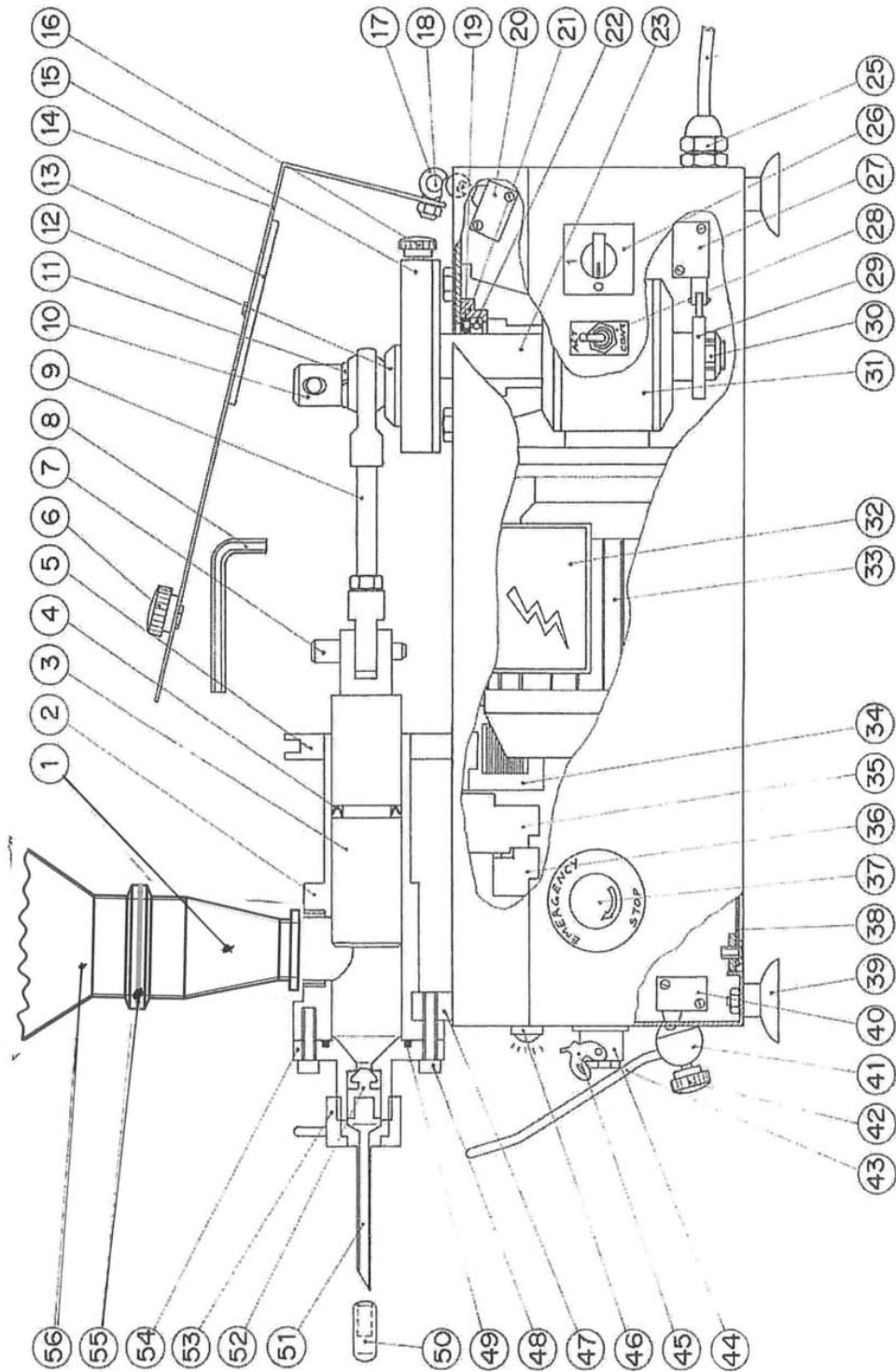

Exploded View of the Machine

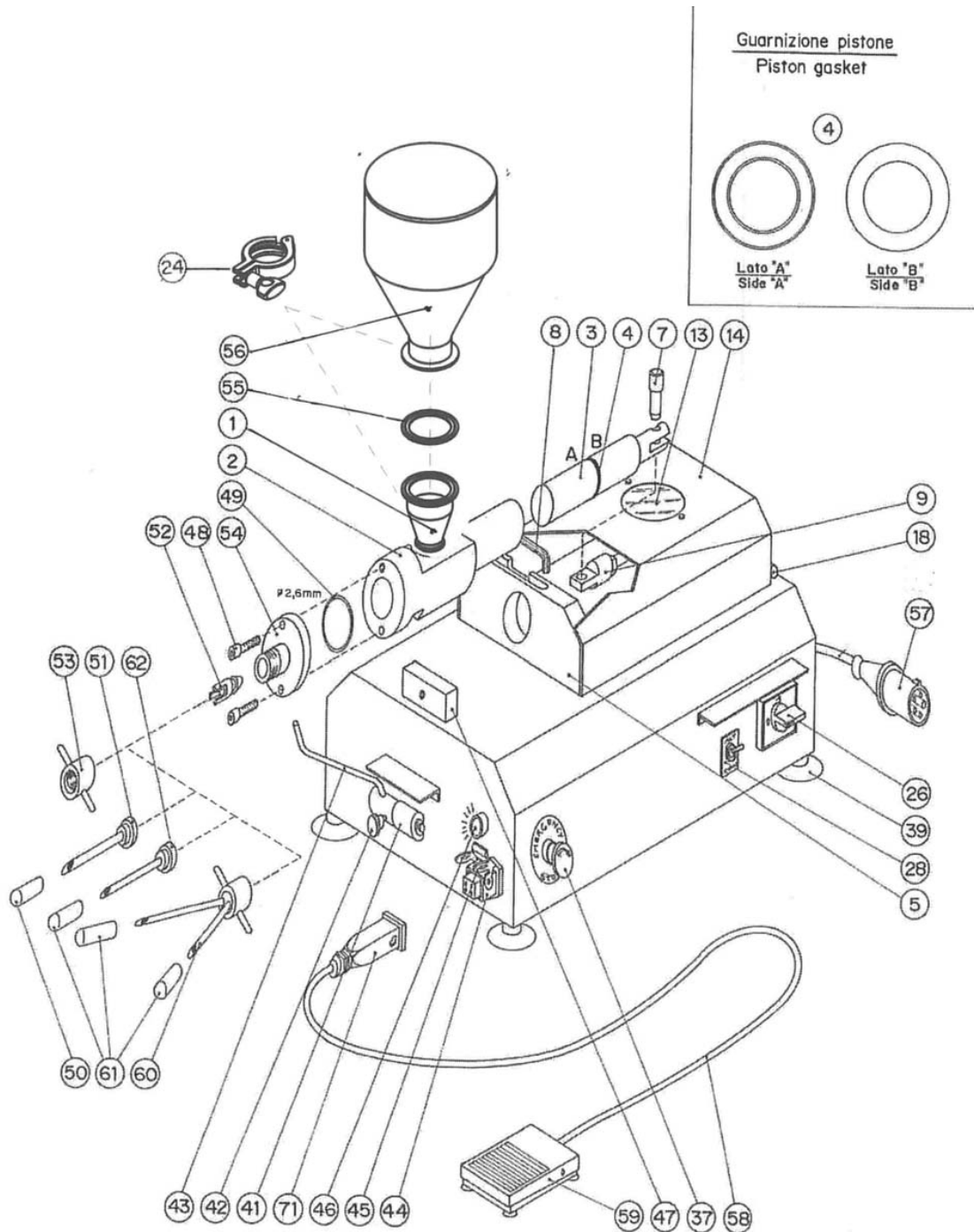

MADE IN ITALY

Reference numbers for spare parts syringe

- 71- Plug
- 81- Electrical cable
- 82- Stainless steel band
- 83- Knurled screw
- 84- Gasket o-ring
- 85- Connection
- 86- Pipe
- 87- Knurled screw
- 88- Injection pipe
- 89- Hook
- 90- Grip
- 91- Switch button
- 92- Valve
- 93- Spring
- 70- Needle

Functional diagram of the Syringe

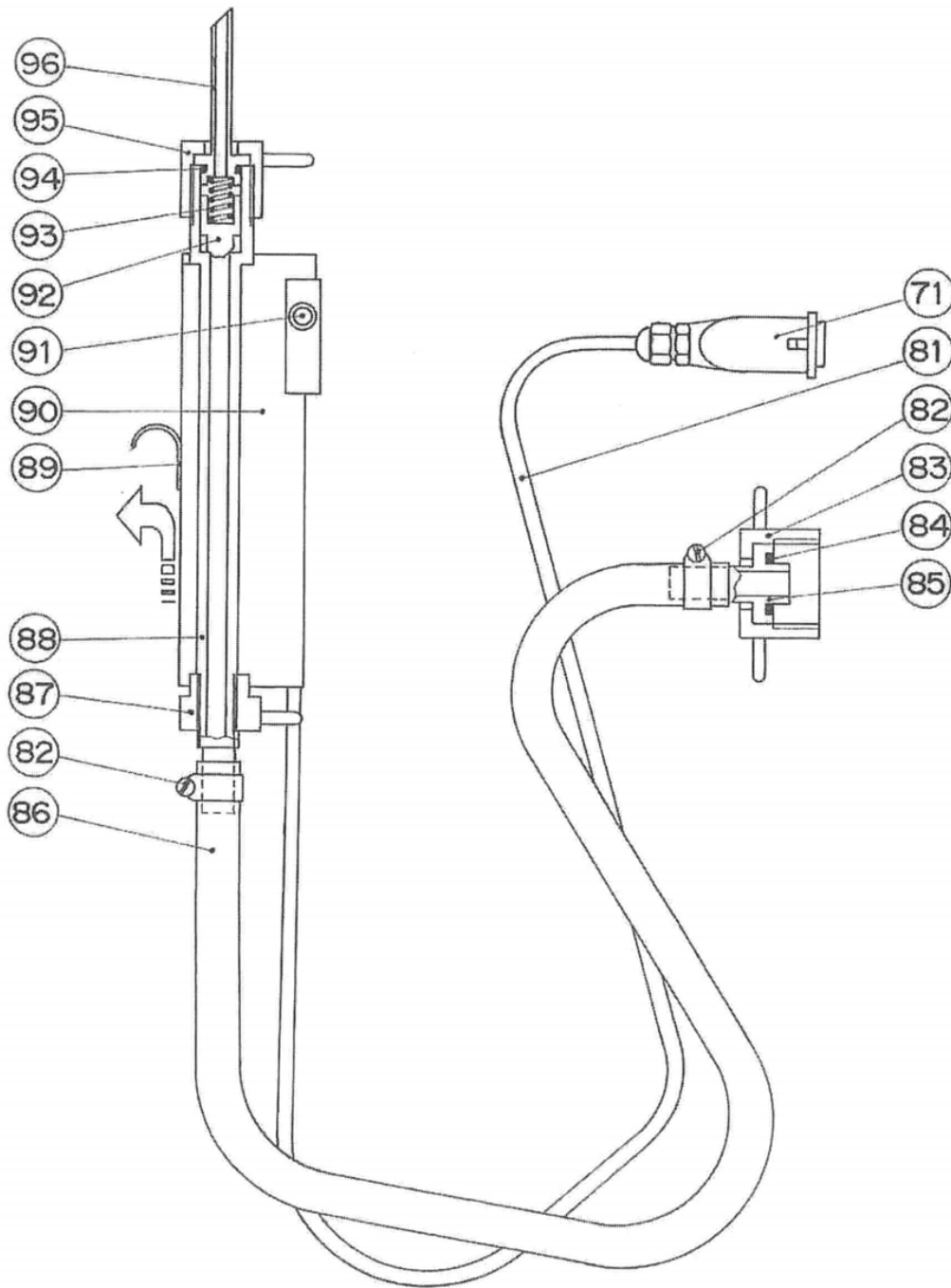

Exploded View of the Syringe

